

CVOA Newsletter



Continental Village Owners Association (847) 244-9829

Newsletter December 2021

Board of Directors

2021 / 2022

President,
Tim Parker

Vice President,
Lisa Haith

Treasurer,
Robin Richter

Secretary,
Lisa Aruguete

Directors,
Ellis Swopes
Joyce Wright
Kelly Rzymowski

Happy Holidays

CVOA – 2021 Holiday

Porch Decorating Contest

The Rules are Simple: No Drilling Holes in the buildings

- 1) Participation is open to all CV residents
- 2) Contest Fee: Free
- 3) Contest Exterior Decorations Only - including in windows that are visible
- 4) Judging will be based on curb appeal as viewed from parking lot.
- 5) Judging Criteria includes unique design, creative use of lights & decorations
Storyline or themes, display & placement, overall presentations,
All decorated porches will be judged.

Judging will take place on December 18, 2021 (P.M.)

Your entry # will be your address: Example: 4111 Continental = "4111C"

4 Prizes will be awarded

First Prize \$100.00 - Second Prize \$75.00 - Third Prize \$50.00 – Fourth \$25.00

Dates to Remember

December Board Meeting
12-21-21
January Board Meeting
1-18-22

St Nicholas Day
Dec 6th, 2021

Christmas Day
Dec 25th, 2021

Chanukah
Nov 29, / Dec 6th
Festival of Lights

Kwanzaa
Dec 26th, 2021 / Jan 1st, 2022

Happy New Year 2022



Happy Holidays



Snow Parking

In working with the City of Waukegan to get a handle on the plowing of the snow on Brentwood Ln & Abington, the City of Waukegan will try and push our snow down to the west end of Brentwood so it does not pile up at the end of the courts. That is the Goal.

Other areas to move snow include the 1st three spaces in the over flow parking at the east end of Brentwood.

Winter Car Kit: Blanket, Water, Flashlight, Screw Drivers, Snow Scrapper Jumper Cables, Snow Shovel

Check your tire pressure, oil & washer fluid. Don't Forget to Lock your Car Doors & Don't leave valuables in sight.

Continental Village Owners Association

4177 Continental Dr.
Waukegan, IL 60087

Phone
(847) 244-9829

Fax
(847) 244-1549

E-mail
cvoa@att.net

Office Hours:
Mon, Wed, Friday
8:00 a.m. to 2:00 p.m.
Saturday
9:00 a.m. to 3:00 p.m.

Goals for 2022
Renovate Court #5
(Two Buildings)

Continue Large Porch
Renovations
(Buildings with Garages)

Reseal & Stripe All Parking
Lots.

Various Concrete Repairs
Various Tree Planting

Vehicle Stickers

All Vehicles on Continental Village Properties (Parking Lots & overflow spaces,) must have a Vehicle Sticker, or they will be ticketed and or towed at your expense.



New Dog Registration Rule.
If you own a Dog, the Board of Directors is implementing a dog registration form.

Snow Notice

This year's Snow Season, the Snow Contractor is going to use the first 3 spaces in the overflow parking at the East end of Brentwood Ln. (Left Side) between Court's # 1 & # 2 to park snow equipment.

They will also be pushing some of the snow between the 2 courts. Hopefully for a better clean up. This way if we do not have a heavy snow we do not have to truck the snow all the way down to the West end of Brentwood Ln.

Please do not park in these spaces. They will be marked.

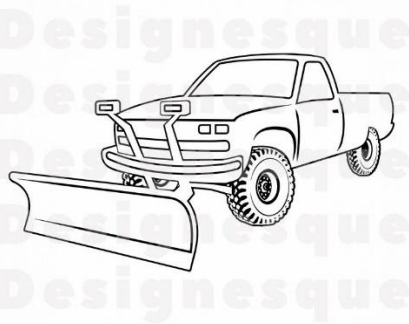

+++++

Are you signed up to receive our e-mail Blasts? If you want to receive last minute important alerts please send us your e-mail request to cvoa@att.net.....

Please call the office immediately to report if any parking lot lights are not working.

Garbage Cans: Please note that the garbage cans can now be moved to their winter locations (Front Porch)

Snowman



“Without a sense of caring, there can be no sense of Community”

Anthony J. D'Angelo